



# TVL201

## 3-WHEEL DUAL-DRIVE COUNTERBALANCE FORKLIFT 2000KG

2000 kg 6000 mm 80 V Li-Ion



**Narrow Aisle:** This counterbalance forklift can be used for a range of work applications including indoor warehousing and narrow aisle, with a turning radius starting from 1450mm for TVL151 to 1585mm for TVL201.

**Loading/Unloading:** It offers great performance in loading and unloading tasks at docks or side bay lorries, supported by its powerful 80V battery. Ideal for the rental business due to its opportunity charging capability.

SPECIFICATION	REF	UNIT	VALUE
Battery type			Li-Ion
Battery nominal capacity K5		Ah	205
Battery voltage		V	80
Rated capacity	Q	kg	2000
Load centre distance	c	mm	500
Service weight		kg	3429
Height, mast lowered	$h_1$	mm	2075
Lift	$h_3$	mm	3000
Height, mast extended	$h_4$	mm	4055
Overall length	$l_1$	mm	3020
Overall width	$b_1/b_2$	mm	1170
Length to face of forks	$l_2$	mm	1950
Fork dimensions	s/e/l	mm	40X122X1070
Turning radius	Wa	mm	1585
Manufacturer			EP
Model designation			TVL201

# Features

## 80 Volt System Offering Powerful Performance

The 80 voltage 2\*5.0 kW dual drive motors offer higher power efficiency than regular 48 voltage, thus the TVL series has greatly enhanced its productivity of 6 working hours per charge.



## Large Workspace

Due to the compact size of EP lithium battery and the ergonomic configuration of the control levers and the foot brake pedal, the small truck offers spacious legroom of 394mm and delivers the best in operation comfort.

## Compact Truck Size

The TVL series features a small turning radius, 1450mm of TVL151, 1550mm of TVL181 and 1585mm of TVL201, which makes it a perfect workhorse for small warehouses with narrow aisles within 3.5 m.



## Integrated Charger

The TVL series forklift comes with a EP Li-Ion battery and a 35A single phase integrated charger with 16 amp plug allowing the truck to be charged at any power outlets (except 10A and 13A civil plug in Switzerland and England).

## Enhanced Mast with Optimal Visibility & Stability

The TVL series adopts the same high-strengthened mast of CPD20L2, offering the best all-around visibility and great stability with less wobbling even fully loaded.



# VDI Chart

	SPECIFICATION	REF	UNIT	VALUE
1.1	Manufacturer			EP
1.2	Model designation			TVL201
1.3	Drive			Electric
1.4	Operator type			Seated
1.5	Rated capacity	Q	kg	2000
1.6	Load centre distance	c	mm	500
1.8	Load distance, centre of drive axle to fork	x	mm	420
1.9	Wheelbase	y	mm	1330
2.1	Service weight		kg	3429
2.2	Axle loading, laden front/rear		kg	4745/684
2.3	Axle loading, unladen front/rear		kg	1359/2070
3.1	Tyres			Solid rubber
3.2	Tyre size, front		mm	200/50-10
3.3	Tyre size, rear		mm	140/55-9
3.5	Wheels, number front/rear (x=drive wheels)			2X/2
3.6	Tread width, front	b <sub>10</sub>	mm	969
3.7	Tread width, rear	b <sub>11</sub>	mm	210
4.1	Tilt of mast/fork carriage forward/backward		°	5/5
4.2	Height, mast lowered	h <sub>1</sub>	mm	2075
4.3	Free lift	h <sub>2</sub>	mm	100
4.4	Lift	h <sub>3</sub>	mm	3000
4.5	Height, mast extended	h <sub>4</sub>	mm	4055
4.7	Height of overhead guard (cabin)	h <sub>6</sub>	mm	2078
4.8	Seat height relating to SIP/stand height	h <sub>7</sub>	mm	1050
4.12	Coupling height	h <sub>10</sub>	mm	600
4.19	Overall length	l <sub>1</sub>	mm	3020
4.20	Length to face of forks	l <sub>2</sub>	mm	1950
4.21	Overall width	b <sub>1</sub> /b <sub>2</sub>	mm	1170
4.22	Fork dimensions	s/e/l	mm	40X122X1070
4.23	Fork carriage ISO 2328, class/type A, B			2A
4.24	Fork carriage width		mm	1040
4.31	Ground clearance, laden, below mast		mm	89

SPECIFICATION		REF	UNIT	VALUE
4.32	Ground clearance, centre of wheelbase	m <sub>2</sub>	mm	92
4.34.1	Aisle width for pallets 1000×1200 crossways	Ast	mm	3315
4.34.2	Aisle width for pallets 800 × 1200 lengthways	Ast	mm	3435
4.35	Turning radius	Wa	mm	1585
5.1	Travel speed, laden/unladen		km/h	13/14
5.2	Lift speed, laden/unladen		m/s	0.33/0.4
5.3	Lowering speed, laden/unladen		m/s	0.38/0.4
5.8	Max. gradeability, laden/unladen		%	10/15
5.10	Service brake			Hydraulic
5.11	Parking brake			Mechanical
6.1	Drive motor rating S2 60 min		kW	5.0X2
6.2	Lift motor rating at S3 15%		kW	11
6.4	Battery nominal capacity K5		Ah	205
6.4	Battery voltage		V	80
6.4.1	Battery type			Li-Ion
6.5	Battery weight		kg	185
6.6	Energy consumption according to DIN EN 16796		kWh/h	5.65
6.7	Turnover output according to VDI 2198			136
6.8	Turnover efficiency according to VDI 2198			25.9
8.1	Type of drive unit			AC
10.1	Operating pressure for attachments		bar	180
10.2	Oil volume for attachments		ℓ/min	25
10.5	Steering design			Hydraulic
10.7	Sound pressure level at the driver's seat		dB(A)	74

## RATED CAPACITIES AND LOAD CENTERES GRAPH

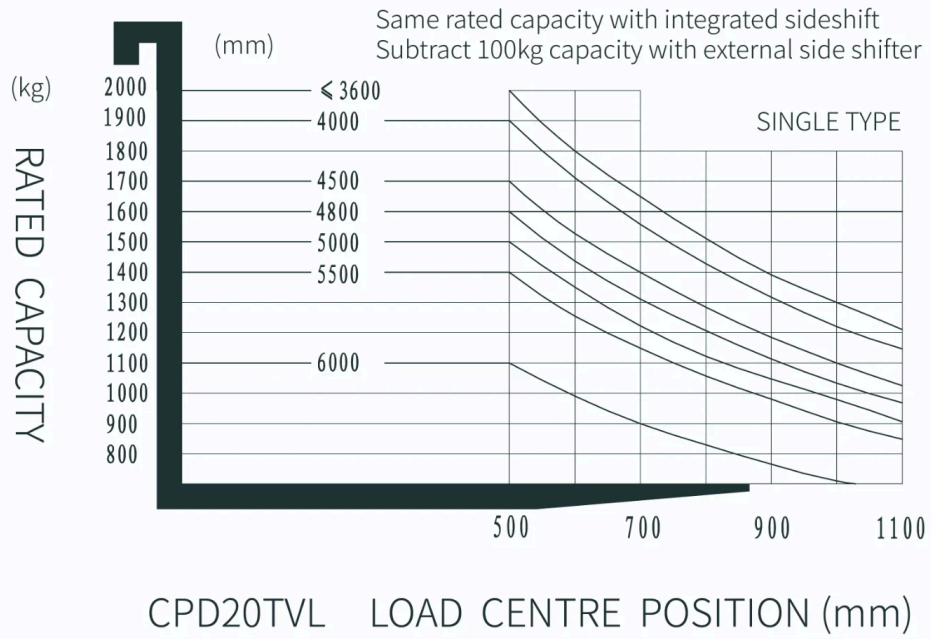

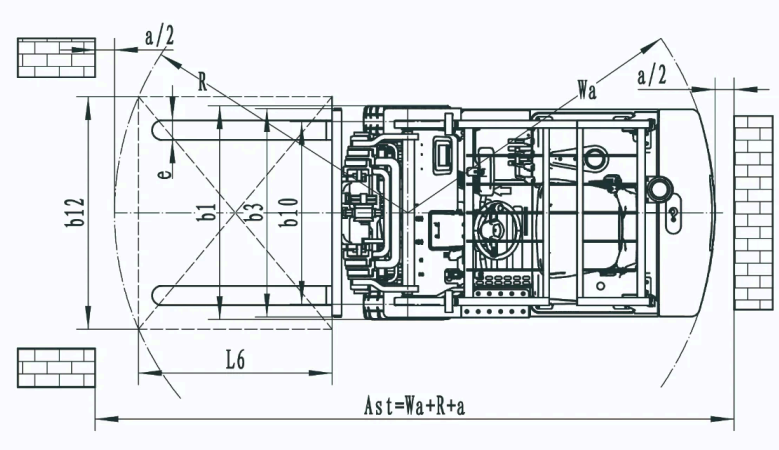
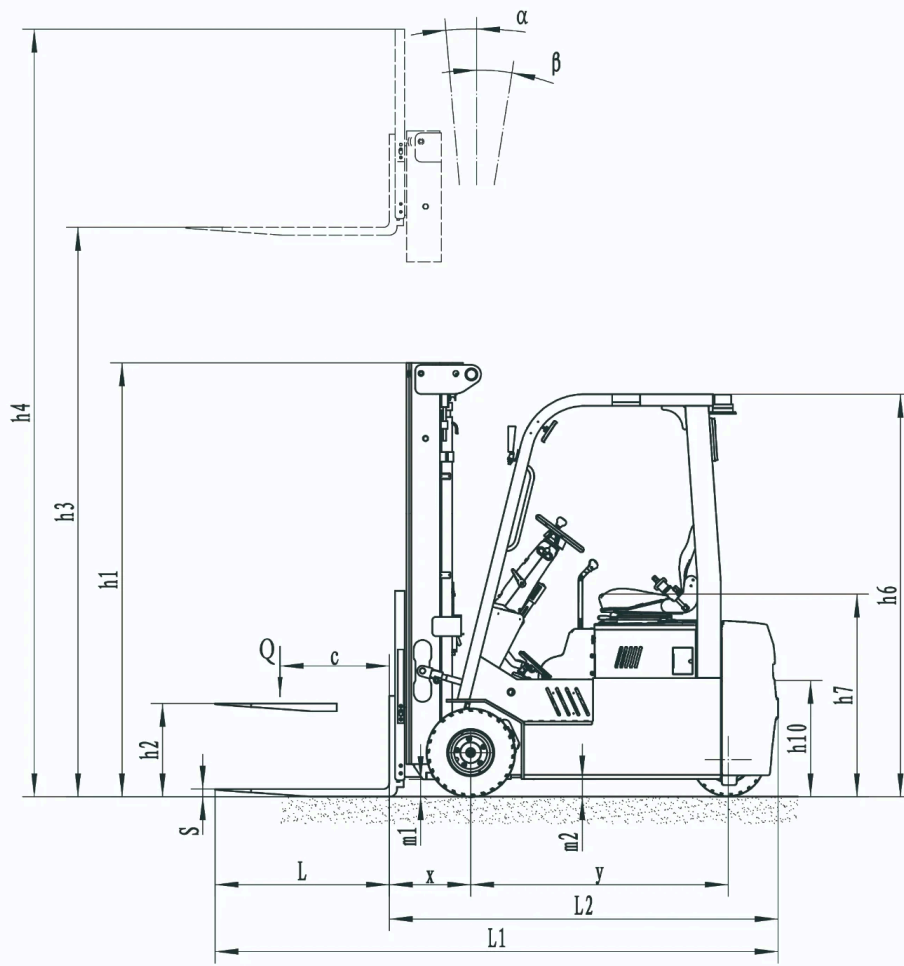

## Mast Options

MAST TYPE	LIFT HEIGHT (H3, MM)	MAST LOWERED HEIGHT (H1, MM)	MAST EXTENDED HEIGHT, NO BACKREST (H4, MM)	MAST EXTENDED HEIGHT, WITH BACKREST (H4, MM)	FREE LIFT HEIGHT, NO BACKREST (H2, MM)	FREE LIFT HEIGHT, WITH BACKREST (H2, MM)
2-Standard Mast	3000	2075	3740	4055	100	100
2-Standard Mast	3600	2375	4340	4655	100	100

MAST TYPE	LIFT HEIGHT (H3, MM)	MAST LOWERED HEIGHT (H1, MM)	MAST EXTENDED HEIGHT, NO BACKREST (H4, MM)	MAST EXTENDED HEIGHT, WITH BACKREST (H4, MM)	FREE LIFT HEIGHT, NO BACKREST (H2, MM)	FREE LIFT HEIGHT, WITH BACKREST (H2, MM)
2-Standard Mast	4000	2455	4740	5055	100	100
3-Free Mast	4500	2140	5240	5555	1430	1115
3-Free Mast	4800	2240	5540	5855	1530	1215
3-Free Mast	5000	2305	5740	6055	1595	1280
3-Free Mast	5500	2475	6240	6555	1765	1450
3-Free Mast	6000	2690	6740	7055	1980	1665

## Options

ITEM	OPTIONS (optional items marked in yellow)
Fork dimension	122*40*1070   122*40*920   122*40*1150   122*40*1200   122*40*1220   122*40*1370   122*40*1500   122*40*1670   122*40*1820
Fork carriage width option	1040mm   Yes and can be customized
Fork carriage height option	1067mm (42in)   1220mm (48in)   1520mm (60in)   Yes and not customized
Front wheel material	Solid rubber   Yes and not customized
Rear wheel material	Solid rubber   Yes and not customized
Battery capacity	150Ah   205Ah   280Ah
Charger	80V-35A single-phase integrated   80V-60A 3-phase integrated   80V-35A single-phase external   80V-65A 3-phase external   80V-100A 3-phase external
Battery display indicator (BDI)	With hourmeter
Seat type	Regular   Premium   Suspension   Suspension+seatbelt logic switch
Attachments	No   Built-in sideshifter   External shifter   Adjustable fork
Traction pin	Yes
Anti-static chain	Yes
Front lamp	LED
Rear lamp	No   LED
Warning lamp	YES
Blue lamp	No   2 front   1 rear   2 front+ 1 rear
Area warning lamp	No   1 left + 1 right (Red)
Rearview mirror	1 in the middle   Add 1 rearview mirror on both sides

ITEM	OPTIONS (optional items marked in yellow)
Buzzer	YES
OPS system	YES
Telematics	No   Yes and not customized
Cabin	No   Basic half cabin   Upgrade half cabin   Full cabin
Wiper water unit	No   Yes, only with cabin and not customized